



DevotiSailing



Negrinautica



# EurILCA EUROPA CUP 2024

ILCA 7 , ILCA 6 & ILCA 4 Classes

2nd May – 5th May 2024

Punta Ala

## SAILING INSTRUCTIONS

Version 29 April 2024

### CO-ORDINATING AUTHORITY

EurILCA: European Region of ILCA

[www.eurilca.org](http://www.eurilca.org) email: [entryeurilca@gmail.com](mailto:entryeurilca@gmail.com)

### Preamble:

EurILCA reminds us that sporting events are above all a space for exchanges and sharing open and accessible to all. As such, competitors and support persons are asked to behave in all circumstances, on land and on the water, in a courteous and respectful manner regardless of origin, gender or sexual orientation. from other participants

### 1. RULES

- 1.1. The regatta will be governed by the *rules* as defined in the Racing Rules of Sailing.
- 1.2. No national authority prescriptions will apply.
- 1.3. The ILCA class rule 7(a) is restricted as follows: Only one person shall be on board whilst racing. The person shall be named on the entry form.
- 1.4. If there is a conflict between languages the English text will take precedence.
- 1.5. Races will be started with no less than 5 knots wind.
- 1.6. RRS Appendix P, Special Procedures for Rule 42, will apply. See SI 15.1.
- 1.7. RRS Appendix T will apply.
- 1.8. [SP] Standard Penalty: The Standard Penalty is 10% of the points of the DNF of the fleet where the boat is competing, unless stated otherwise.
  - 1.8.1. An additional list of Standard Penalties may be published on the ONB before the start of 1<sup>st</sup> race.

### 2. NOTICES TO COMPETITORS

- 2.1. Notices to competitors will be posted on the online official notice board that can be found in the following link: <https://www.racingrulesofsailing.org/documents/7890/event>
- 2.2. A coaches meeting will be held the first day of racing at 10:30 hrs at the event tent in front of race office.

### 3. CHANGES IN SAILING INSTRUCTIONS

- 3.1. Any changes to the Sailing Instructions will be posted before 09:00 on the day it will take effect.
- 3.2. The scheduled time for the warning signal of the first race for each day shall be specified in a notice posted by 20:00 on the day before it will take effect.
- 3.3. Any reassignment of events or fleets to course areas will be posted before 09:00 am on the day it will take effect,

### 4. SIGNALS MADE ASHORE

- 
- 4.1. Signals made ashore will be displayed at the official flagpole located on the beach, in front of the launching channel near to the boat park.
  - 4.2. **[DP][NP]** Flag D: No boat shall leave her berthing area until this signal is made. When displayed with one sound means "The warning signal will be made not less than 60 minutes after flag D is displayed".

## 5. BOATS AND EQUIPMENT

- 5.1. In the event of damage, boats and equipment may only be substituted with the written permission of the technical committee or race committee.
- 5.2. **[DP] [NP]** If the damage occurs later than 90 minutes before the first scheduled start on a racing day and before the start of the last race of the day, provisional verbal permission shall be obtained from the technical committee or race committee. The written permission of the technical committee or race committee shall be obtained before the end of Protest Time Limit published at the end of the day in which the substitution took place.

## 6. FORMAT OF RACING

- 6.1. The ILCA 7 class will sail in one fleet,
- 6.2. ILCA 6 class will be divided in 3 fleets with have separate starting procedure.
- 6.3. ILCA 4 class will be divided in 3 fleets with have separate starting procedure.
- 6.4. The event consists of a single series.
- 6.5. The class might be split into fleets.
- 6.6. A pair number of races of a class constitute a series,
- 6.7. A single series is divided into a qualifying and a final series in accordance with the qualifying and final series formats (see si addendum a).
- 6.8. There are 8 races scheduled for each class. If less than 4 races are completed in qualifying series, there can be more than 4 races sailed in final series to reach the total number of 8 races

## 7. SCHEDULE OF RACES

- 7.1. The scheduled time for the first warning signal for the first race of the first day is 13:00.
- 7.2. On the last day, no more than 2 races may be scheduled and no warning signal for any fleet will be made after 15:30 hrs.

## 8. CLASS FLAGS

- ILCA 7:** Fleet Class flag (white flag with ILCA logo)
- ILCA 6:** Fleet Class flag (green flag with ILCA logo)
- ILCA 4:** Fleet Class flag (yellow flag with ILCA logo)

## 9. RACING AREAS

- 9.1. The approximate Racing area will be posted on the official notice board / Appendix 1  
**Alpha area: ILCA 7- ILCA 4 fleets**  
**Bravo area: ILCA 6 fleets**

## 10. THE COURSES

- 10.1. The SI Addendum A shows the courses, including the approximate angles between legs, the order in which marks are to be passed, and the side on which each mark is to be left.
- 10.2. Before the warning signal for each fleet, the race committee will display course signals.
- 10.3. No later than the warning signal, the race committee signal boat may display the approximate compass bearing of the first leg. Failure to do it, will not be grounds for redress. This changes rule 62.1(a).
- 10.4. The course may be shortened at any mark provided that at least 3 legs have been completed.

- 10.5. If one mark of the gate is missing, the remaining mark shall be rounded to port.  
 10.6. Marks will be described in the SI Addendum A.

## 11. THE START

- 11.1. The starting line will be between two staffs displaying an orange flag on the race committee vessel on the right side of the line and the pin vessel on the left side.  
 11.2. [DP] A buoy may be attached to the race committee starting vessel ground tackle. Boats shall not pass between this buoy and the race committee starting vessel at any time.  
 11.3. [DP] Boats whose warning signal has not been made shall sail at least 100 meters away leeward of the starting line and its extensions during the starting sequence for other races.  
 11.4. A boat starting after 4 minutes from her starting signal will be scored DNS without a hearing. This changes rules A.4 and A.5.  
 11.5. To alert boats that a race or sequence of races will begin soon, the orange starting line flag will be displayed with one sound at least five minutes before any other procedure.  
 11.6. Starting order and Fleet flags:

### Racing Area Alpha

| Fleets                                 | Fleet Flags    | Start Sequence        | Course |
|--|----------------|-----------------------|--------|
| ILCA 7 – Single/ White sleeve          | ILCA 7 (White) | 1 <sup>st</sup> Start | Outer  |
| ILCA 4– Yellow/Gold with Yellow sleeve | Yellow         | 2 <sup>nd</sup> Start | Outer  |
| ILCA 4– Blue/Silver with No Sleeve     | Blue           | 3 <sup>rd</sup> Start | Inner  |
| ILCA 4– Red/Bronze with Red Sleeve     | Red            | 4 <sup>th</sup> Start | inner  |

### Racing Area Bravo

| Fleets                                 | Fleet Flags | Start Sequence        | Course |
|--|-------------|-----------------------|--------|
| ILCA 6– Yellow/Gold with Orange sleeve | Yellow      | 1 <sup>st</sup> Start | Outer  |
| ILCA 6– Blue/ Silver with Blue sleeve  | Blue        | 2 <sup>nd</sup> Start | Outer  |
| ILCA 6– Red/Bronze with No sleeve      | Red         | 3 <sup>rd</sup> Start | Inner  |

**Failure to follow this sequence or course will not be grounds for redress (this changes RRS 62.1(a)).**

### 11.7. Starting under Black Flag Rule Penalty

Rule 30.4 is modified adding the follows: sail numbers will be displayed for at least 3 minutes. A long sound signal will be made when the numbers are displayed.

## 12. CHANGE OF THE NEXT LEG OF THE COURSE

- 12.1. When it is not possible to change the position of the original marks, the course may be reset using one or more new marks. When new marks are already in use, the course may be adjusted using original marks.  
 12.2. Except at a gate, boats shall pass between the race committee boat signalling the change of the next leg and the nearby mark, leaving the mark to port and the race committee vessel to starboard. This changes rule 28.1.

---

### 13. THE FINISH

The finishing line will be between a staff displaying a blue flag on a race committee vessel and the finishing mark described in the SI Addendum A.

### 14. TIME LIMITS AND TARGET TIMES

- 14.1. The length of the course will be set for a target time of 50 minutes. Failure to meet the target time will not be grounds for redress. This changes rule 62.1(a).
- 14.2. Boats failing to finish within 20 minutes after the first boat sails the course and finishes will be scored Did Not Finish without a hearing. This changes rules 35, A.4 and A.5.
- 14.3. If no boat rounds mark 1 within 20 minutes the race shall be abandoned.

### 15. PENALTY SYSTEM

15.1. **Appendix P, Special Procedures for Rule 42**, will apply with the following changes:

- 15.1.1. If a first penalty is after a boat has crossed the finish line, the penalty will be a 10% Scoring Penalty of the DNF without a hearing calculated as stated in RRS 44.3(c) but not more than a DSQ. This changes Appendix P 2.1, RRS 35, A4, A5.

### 16. MEASUREMENT PENALTIES

- 16.1. [NP] Measurement protests will only be accepted from technical committee, race committee or international jury. This changes RRS 60.1(a)
- 16.2. [SP] If a boat is sailed without a centreboard stopper, or with no mast retention line attached (class rule 3(b) xi), a scoring penalty of 30% of the score for did not finish rounded to a whole number (rounding 0.5 upward) will, without a hearing, be added to the boats score in the last completed race in which she was racing without a centreboard stopper or the retention line. However, she shall not be scored worse than DNF. This changes RRS 63.1 and RRS A5.
- 16.3. [SP] If a sail, top mast, or bottom mast has been changed prior to a race without the permission required by SI 5.2 the sailor will be disqualified without a hearing from the last completed race when the change was used. This changes rule 63.1.
- 16.4. [DP] Penalties for Class Rules infringements that are not marked as [SP] will be at the discretion of the International Jury

### 17. SCORING AND ARBITRATION PENALTIES

- 17.1. Scoring penalties will be applied according to RRS 44.3
- 17.2. A scoring penalty in a split fleet will be based according SI Addendum A – 1.7.

### 18. PROTESTS AND REQUEST FOR REDRESS

- 18.1. Hearing requests shall be lodged using the online form, by clicking the “+” symbol on the ONB, otherwise they will be invalid. Once the request has been sent, it will immediately appear on the ONB. This changes RRS 61.2, 61.3, 62.2, 66.
- 18.2. If the system is not working, a screenshot of the Request of a hearing shall be attached to the email to the international jury chairman: itatm8@gmail. The request for a hearing will be insert into the online system and scheduled as soon as reasonably possible.
- 18.3. The time limit for the protests and/or to present the penalty form for each fleet is 60 minutes after the finishing of the last boat in the last race of the day or the RC signal indicating that there will be no other races today, whichever is later for that fleet.
- 18.4. Any written report alleging misconduct shall be sent by email to the jury chairman itatm8@gmail.com
- 18.5. Protest hearings will be held in the Jury office, located on the left side of race office.
- 18.6. The hearing schedule will be posted online on the official notice board as soon as possible after receiving the request.

- 
- 18.7. Parties can be invited to arbitration or to a hearing before the end of the Protest Time Limit.
  - 18.8. Intention to protest initiated by race committee or technical committee or the international jury will be posted on official notice board to inform boats according to RRS 61.1(b).
  - 18.9. A list of boats that have been penalized under Appendix P will be posted online on the official notice board.
  - 18.10. On the last scheduled day of racing or/and of the qualifying series, the time limit to ask for reopening is 30 minutes after the decision has been communicated to the party.
  - 18.11. Decisions of the international jury will be final as provided in rule RRS 70.5
  - 18.12. [DP] the notation '[DP]' in a rule in the SI means that the penalty for a breach of that rule may be less than disqualification at the discretion of the protest committee,. (Penalties for breaches of class rules, or rules in the NOR or Sis)
  - 18.13. [NP] denotes a rule that shall not be grounds for protests by a boat. This changes RRS 60.1(a)
  - 18.14. [SP] denotes a rule for which a standard penalty may be applied by the race committee technical committee without a hearing or a discretionary penalty applied by the international jury with a hearing; this changes RRS 63.1 and A5.1.
  - 18.15. A list of breaches and the associated standard penalties will be posted on the Official Notice Board. However, the race committee / technical committee may protest a boat when they consider the standard penalty to be inappropriate. This changes RRS 63.1 and Appendix A5.

## 19. [DP] [NP] EQUIPMENTS AND MEASUREMENT CHECKS

A boat and equipment may be inspected at any time for compliance with the class rules, as wet clothing rules at the discretion of the technical committee, race committee or international jury.

## 20. [DP] [NP] SAFETY REGULATIONS

- 20.1. The race committee may protest a boat for a breach of these safety regulations. This changes RRS 60.2
- 20.2. Competitors shall wear personal flotation devices at all times when afloat, except briefly while changing or adjusting clothing or personal equipment. According RRS 40.1
- 20.3. Competitors who require assistance from rescue boats should wave one arm with hand open. If no assistance is required, the arm should be waved with fist closed.
- 20.4. If necessary, a competitor may be ordered to abandon his or her boat and board a rescue vessel.
- 20.5. [NP] [DP] Any competitor who has taken a penalty under RRS 44.1, who has retired for breaking a rule, who wishes to be considered as retired (RET) after crossing the finish line, shall fill the online form clicking on the "+" symbol on the ONB. Failing to do so the penalty could be considered as not taken. It is not required to file this form if you took a two turns penalty given by the PC under RRS P2.1.
- 20.6. Flag V, when race committee boats displayed flag V, all team and support boats shall listen to the security communication with safety leader of the racing area in the dedicated VHF channel.
- 20.7. Boats shall avoid commercial traffic and shall cross shipping channels at right angles only.
- 20.8. [SP] CHECK IN  
The tracking system dongle provided by Metasail SHALL be securely worn all time while afloat.  
**If the "V" flag is displayed ashore each competitor shall sign-in on his tracking dongle number on a desk close to the slipway / beach.**
- 20.9. The race office phone number is: **+39 349 881 6427**

## 21. SCORING

- 21.1. When less than 4 races have been completed, a boat's regatta score will be the total of her race scores.
- 21.2. When 4 or more races have been completed, a boat's regatta score will be the total of her race scores excluding her worst score.

## 22. [DP] [NP] ACCREDITED TEAM AND SUPPORT PERSONS/ VESSELS

- 22.1. Accredited vessels are the vessels having filled the accreditation form online at [https://eurilca.eu/documents/326/Team\\_boat\\_accreditation.pdf](https://eurilca.eu/documents/326/Team_boat_accreditation.pdf). Only accredited vessels can go afloat and approach the sailing area and sailors. Team and support vessels shall, at all times when afloat, be clearly identified by the white flag with black or red number, provided by the OA to each support person at registration.
- 22.2. Each support vessel shall carry at least three hazard warning tapes for the purposes of SI 20.4. , marking abandoned boat. The tape will be available at the race office.
- 22.3. Each support vessel is required to carry a VHF radio capable of transmitting and receiving all international ship-to-ship channels.
- 22.4. [SP] VHF Channel **69** for the Alpha area and **74** for the Bravo area will be use as communication channel between Race Committee and coaches/ team leaders on the water.

## 23. SUPPORT VESSEL MOVEMENT

Except when participating in rescue operations support vessel shall stay outside the racing area during a race, that is **from the time of the first warning signal until all boats have finished or the race committee signals a postponement or abandonment of all fleets without the intention to start a next race soon (orange down)**. In addition when any boat is racing between mark 5 and the finish any support vessels shall remain 100m to windward of the finish line or when coming from mark 4 shall reduce to idle speed when crossing a line directly downwind starting at mark 5 (red zone)."

It does apply to the 2 types of courses who are used.

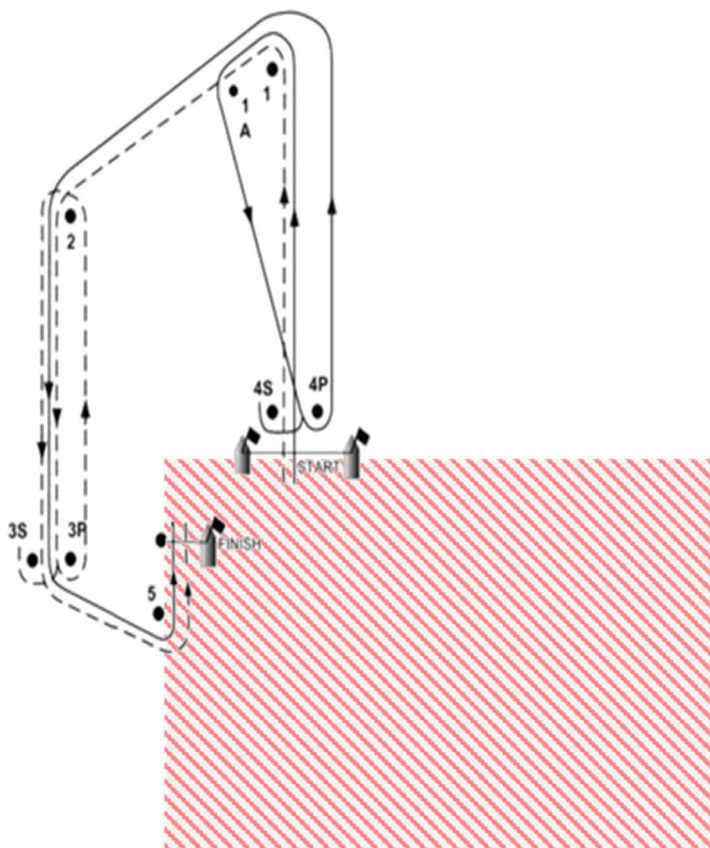

- 23.1. [SP] [DP] [NP] Support vessel drivers and crews shall wear a personal flotation device or other adequate personal buoyancy securely fastened at all times when afloat except briefly while changing or adjusting clothing or personal equipment. Wet suits and dry suits do not constitute adequate personal buoyancy. When the support vessel engine is running Support vessel drivers



---

**shall be connected to a device that will stop the engine (Kill Cord) if the boat driver falls out the boat or is otherwise not in control of the boat**

**23.2.** When not in use, support vessels shall be appropriately berthed at the sailing venue in the allocated areas for support vessels for the entire time that these regulations apply.

**23.3.** Support vessels shall comply with local harbour and marina regulations, including speed limits.

**23.4. Accomplishments**

**If an accredited boat does not comply with these instructions, or its crew has an incorrect behaviour, the accreditation may be suspended, cancelled, and/ or no more issued in next Europa Cup of the series. That decision may be made by the Jury with the Eurilca Representative.**

**24. [DP] [NP] INSURANCE**

Each participating boat shall be insured with valid third-party liability insurance with a minimum cover per event as stated in the NOR.

**25. LIABILITY**

**The host sailing club, the National Authority and EurILCA, their officers, members and volunteers do not accept liability for loss of life or property, personal injury or damage caused by or arising out of the EurILCA Europa Cup Regattas and competitors take part in the Regattas entirely at their own risk. The establishment of the Notice of Race and the Sailing Instructions in no way limits or reduces the complete and unlimited responsibilities of a competitor being solely and entirely responsible for the management of a boat he or she is sailing. A competitor must be of good health and a competent sailor capable of sailing an ILCA dinghy in strong winds. It is the responsibility of each sailor to decide to participate in a race or to continue racing.**

**26. RIGHTS TO USE NAME AND LIKENESS**

By participating in this event, competitors automatically grant to the organizing authority, the Media services providers and the event sponsors the right, in perpetuity, to make, use, and show, at their discretion, any photography, audio and video recordings, and other reproductions of them made at the venue or on the water from the time of their arrival at the venue, until their final departure, without compensation for the purpose of news reporting, regatta documentary, advertising to promote the regatta, the national or the international class association or sailing, and advertising where the above pictures/video recordings/etc. are shown in the context of sailors/participants competing in Europa Cup Regattas.

**27. DRONE NO FLY ZONE**

Italy is a Country with strict regulation for flying drones that can be found:

<https://www.enac.gov.it/sicurezza-aerea/droni/normativa-droni>,

**Personal Drone flights are strictly forbidden while racing except when a pilot can prove to comply with all requirement of ENAC.** In such case the pilot will obtain a written permission by OA.

## **Addendum A–EurILCA Europa Cup**

**1. COMPETITION FORMAT**

**1.1.** Where a fleet is bigger than 80 boats, (or close to 80 at discretion of the Race Committee) it can be split into groups.

**1.2.** The organising authority will divide the boats in the split fleet(s) into groups of, as nearly as possible, equal size.

**1.2.a.** When in a fleet there is a presence of at least 40 girls or ladies group can be constituted,

**1.2.b.** Each appropriate Fleet will be split into 2 groups called Yellow and Blue or in 3 groups called Yellow, Blue and Red; or in 4 groups with the green group.

- 1.2.c. Boats will be possibly reassigned to groups each day after racing based on the overall available results.
- 1.2.d. The polling will be made with scoring system, with the alternate option.
- 1.3. The notice of groups will be posted online on the official notice board as soon as possible before the first race of the day. The starting signal will be made no earlier than 60 minutes after the time of the posted notice.
- 1.4. If all groups of a split fleet have not completed the same number of races by the end of a day, the groups with fewer races will continue racing the following day until all groups have completed the same number of races.
- 1.5. If at the end of the regatta some groups of a split fleet have more race scores than others, scores for the most recent race(s) will be excluded so that all groups of that fleet have the same number of race scores. That S.I. will be applied also at the last day to define the groups for finals, see next S.I.
- 1.6. When at least 4 races were sailed for all groups, the following days the fleet will be divided in Gold and Silver fleets (and bronze and emerald if in case) and raced in "finals" format. See NOR 7.3. Different final-series groups need not have completed the same number of race.
- 1.7. RRS A5.2 is changed so that the scores for each class are based on the number of boats assigned to the largest fleet.

## 2. GROUPS IDENTIFICATION

- 2.1. If a fleet is split into groups, the class flag for each group will be the class flag with a coloured flag corresponding to the group colour.
- 2.2. If a fleet is split into groups, each competitor in that fleet will be issued with a sleeve corresponding to the allocated group. The band shall be placed around the lower mast between the gooseneck and boom vang fitting.
- 2.3. In case of finals both flags and coloured bands / Flag will be as per gold=yellow; silver=blue; and bronze=red; emerald=green.

## 3. OFFICIAL BOATS

Official boats will be marked as follows:

|                                 |                        |
|---------------------------------|------------------------|
| Race Committee                  | With flag „CVPA“       |
| Jury                            | With flag „J-“         |
| Technical Committee             | With flag „M“          |
| Rescue / First Aid /<br>Medical | With flag „ Red cross“ |
| Media / Press                   | With flag „P“          |

## 4. COURSE DIAGRAM

### 4.1 STANDARD COURSE

This course allows the consecutive starts of fleets.

**Course 1** Outer Loop: I.C. Numeral **pennant 1** displayed.

**Course 2** Inner Loop: I.C. Numeral **pennant 2** displayed

That is used when you have up three fleets or 4 fleets of small size.



The diagram shows the course, the order in which marks are to be passed and the side on which each mark is to be left.

The leg between marks 3S/3P and mark 5 may be laid shorter than the leg between mark 1 and mark 2 so that the finish line is not directly to leeward of the start line.

Outer: .....1, 2, 3S/3P (gate), 2, 3S/3P (gate), 5, FINISH

Inner: .....1, 1A, 4S/4P (gate), 1, 2, 3S/3P (gate), 5, FINISH

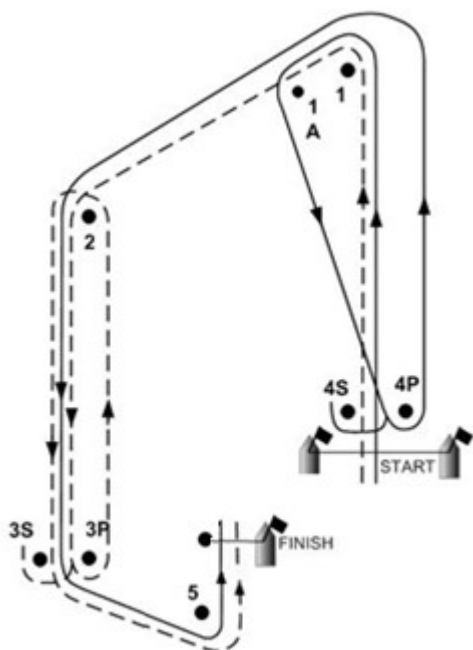

**ALPHA AREA MARKS: COURSE ILCA 7 e 4**

|                |   |
|----------------|---|
| Mark 1         | Yellow inflatable buoy                        |
| Mark 1a        | White inflatable buoy                         |
| Mark 2         | Yellow inflatable buoy                        |
| Mark 3s/3p     | Yellow inflatable buoy                        |
| Mark 4s/4p     | Orange inflatable buoy                        |
| Mark 5         | Orange inflatable buoy                        |
| Starting line  | Vessel with orange flag, rib with orange flag |
| Finishing line | Rib with blue flag , Yellow inflatable buoy   |

**BRAVO AREA MARKS: COURSE ILCA 6**

|                |   |
|----------------|---|
| Mark 1         | Orange inflatable buoy                        |
| Mark 1a        | Orange inflatable buoy                        |
| Mark 2         | Orange inflatable buoy                        |
| Mark 3s/3p     | Orange inflatable buoy                        |
| Mark 4s/4p     | Orange inflatable buoy                        |
| Mark 5         | Orange inflatable buoy                        |
| Starting line  | Vessel with orange flag, rib with orange flag |
| Finishing line | Rib with blue flag , Yellow inflatable buoy   |

**5. [DP] TRASH DISPOSAL**

RRS 47 applies. Trash may be placed aboard support and race committee vessels.

---

**6. [DP] ADVERTISING**

- 6.1. Regulation WS 20 will be applied.
- 6.2. Boats shall display advertising supplied by the organizing authority if applicable. Details shall be specified as follows:

**7. PRIZES**

- 7.1. Prizes are stated by the NOR 15.1.
- 7.2. Prizes will be assigned also if only one race will be sailed. In case of ties the prize will be raffled.
- 7.3. Additional prizes may be introduced.

**8. EVENTUAL FORBIDDEN AREAS**

Omissis

**9. EVENTUAL LOCAL RECOMMENDATIONS**

Omissis

**10. [DP] RADIO COMMUNICATION**

A boat shall neither make radio transmissions while racing nor receive radio communications not available to all boats, except in an emergency or when using equipment provided by the race committee.

# APPENDIX 1 sailing instructions

## EurILCA Europa cup “Racing Areas”

